

REV	DESCRIPTION	DATE
2.00	CHG DIM 3.1 W. 2.9 , CHG SLEEVE FINISH NICKEL W. ALBALOY.	2012/03/06
2.10	NEW DRAWING FRAME	2023/12/27

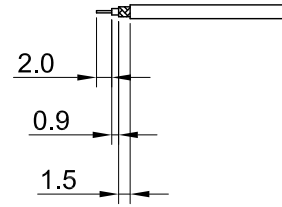

RECOMMENDED STRIP LENGTHS

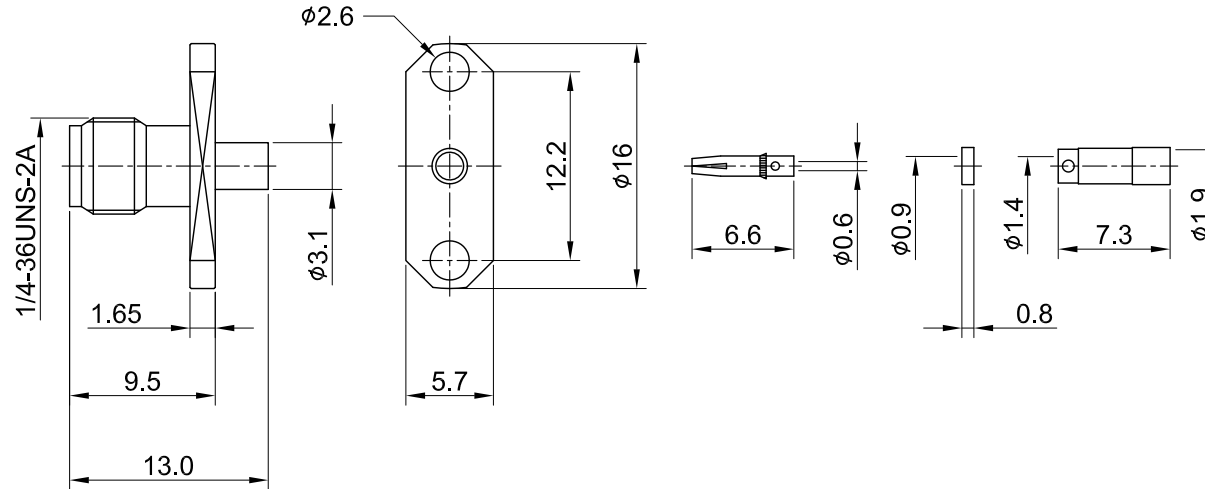

MECHANICAL DATA
 DURABILITY : 500 CYCLES
 TEMPERATURE RANGE : -65°C ~ + 165°C

ELECTRICAL DATA
 FREQUENCY RANGE: DC~6GHZ
 IMPEDANCE : 50Ω
 VSWR : 1.3 MAX.
 WORKING VOLTAGE : AC 170V
 WITHSTANDING VOLTAGE : AC 500V
 INSULATION RESISTANCE : 5000 MΩ MIN

TITLE
 SMA(F) 2 holes panel crimp for RG178

05	SLEEVE	BRASS	NICKEL	1
04	INSULATOR B	TEFLON	NONE	1
03	CENTER PIN	Be.Cu	GOLD	1
02	INSULATOR A	TEFLON	NONE	1
01	BODY	BRASS	GOLD	1
NO	DESCRIPTION	MATERIAL	FINISH	Q'TY

DWG NO. C02AF31178007
CUST. P/N: N/A DWG NO: N/A
SHEET 1 of 1 Unit: mm

GENERAL TOLERANCES

.X ±0.2

.XX ±0.2

.XXX ±0.2

ANGLES N/A

DRAWN BY: Kelly 2023/12/27

CHK'D BY: Eileen 2023/12/27

REV. 2.10

DA2312250011