

REV	DESCRIPTION	DATE
2.00	CHG SLEEVE FINISH NICKEL W. ALBALOY	2012/05/31
2.10	NEW DRAWING FRAME	2023/12/28

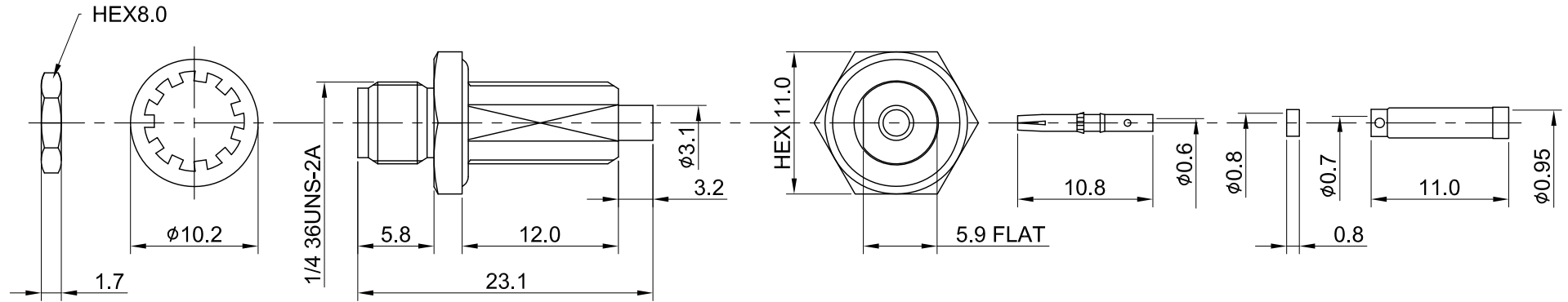
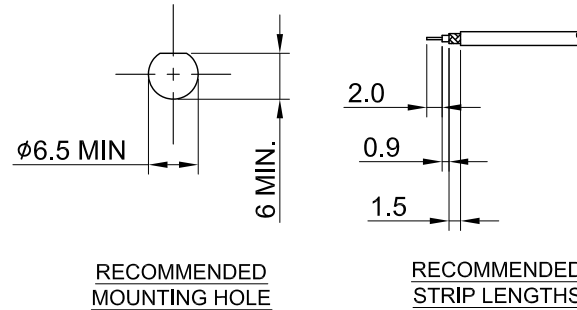

MECHANICAL DATA
 DURABILITY : 500 CYCLES
 TEMPERATURE RANGE : -65°C ~ + 165°C

ELECTRICAL DATA
 FREQUENCY RANGE: DC~6GHZ
 IMPEDANCE : 50Ω
 VSWR : 1.3 MAX.
 WORKING VOLTAGE : AC 170V
 WITHSTANDING VOLTAGE : AC 500V
 INSULATION RESISTANCE : 5000 MΩ MIN

08	SLEEVE	BRASS	NICKEL	1	TITLE SMA(F)bh.(Front Mount)with Oring for 0.81	
07	INSULATOR B	TEFLON	NONE	1		
06	NUT	BRASS	GOLD	1	DWG NO. C02AU31081032	
05	WASHER	BRASS	GOLD	1		
04	GASKET	SILICONE RUBBER	NONE	1	CUST. P/N: N/A DWG NO: N/A	
03	CENTER PIN	Be.Cu	GOLD	1		
02	INSULATOR A	TEFLON	NONE	1	GENERAL TOLERANCES .X ±0.2 .XX ±0.2 .XXX ±0.2 ANGLES N/A	
01	BODY	BRASS	GOLD	1		
NO	DESCRIPTION	MATERIAL	FINISH	Q'TY	SHEET 1 of 1	Unit: mm
					DRAWN BY: Kelly 2023/12/28 CHK'D BY: Maria 2023/12/28 REV. 2.10 DA2312260057	