

| REV | DESCRIPTION | DATE |
|------|-------------------|------------|
| 2.00 | CHG PIN DISIGN | 2023/02/22 |
| 2.10 | NEW DRAWING FRAME | 2024/12/30 |

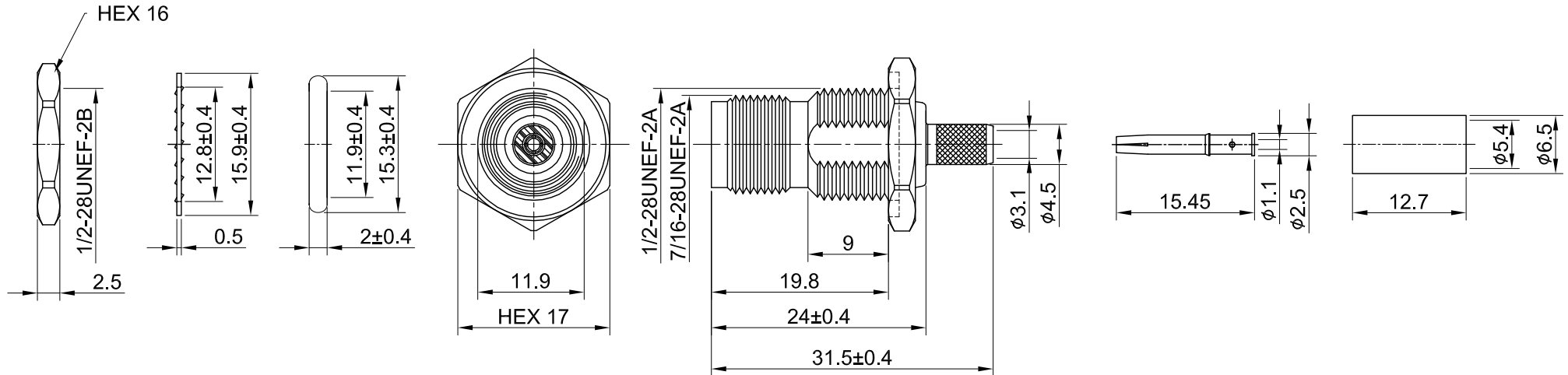
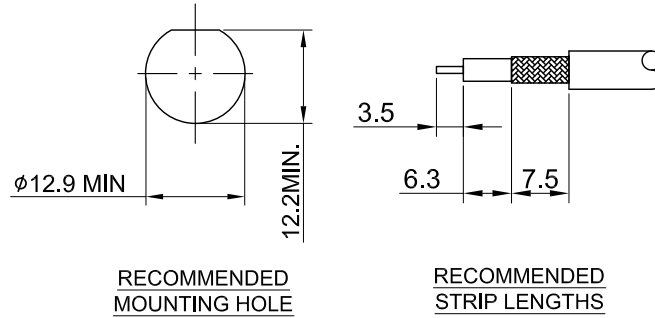

MECHANICAL DATA
 DURABILITY : 100 CYCLES
 TEMPERATURE RANGE : -65°C ~ + 165°C

ELECTRICAL DATA
 FREQUENCY RANGE: DC~6GHz
 IMPEDANCE : 50Ω
 VSWR : 1.5 MAX.
 WORKING VOLTAGE : AC 500V
 WITHSTANDING VOLTAGE : AC 1500V
 INSULATION RESISTANCE : 5000 MΩ MIN

| | | | | | | | | | | | | | | | | | | | | | |
|--------------------|-----------------|-----------------|--------|------|--|--|--------------------|-----------------|------------|---------|-----------------|------------|----------|--|--|-----------|--|--|------------|--|--|
| 08 | NUT | BRASS | NICKEL | 1 | TITLE TNC(F) bh. wOring for RG58, RG58Low Loss | | | | | | | | | | | | | | | | |
| 07 | WASHER | BRASS | NICKEL | 1 | | | | | | | | | | | | | | | | | |
| 06 | O RING | SILICONE RUBBER | BLACK | 1 | DWG NO. C18CD3F058A03D-1 | | | | | | | | | | | | | | | | |
| 05 | FERRULE | BRASS | NICKEL | 1 | | | | | | | | | | | | | | | | | |
| 04 | CENTER PIN | P.BRONZE | GOLD | 1 | CUST. P/N: N/A DWG NO: N/A | | | | | | | | | | | | | | | | |
| 03 | CHASSIS | BRASS | NICKEL | 1 | | | | | | | | | | | | | | | | | |
| 02 | INSULATOR | TEFLON | NONE | 1 | <table border="0"> <tr> <td>GENERAL TOLERANCES</td> <td>DRAWN BY: Kelly</td> <td>2024/12/30</td> </tr> <tr> <td>.X ±0.2</td> <td>CHK'D BY: Chili</td> <td>2024/12/30</td> </tr> <tr> <td>.XX ±0.2</td> <td></td> <td></td> </tr> <tr> <td>.XXX ±0.2</td> <td></td> <td></td> </tr> <tr> <td>ANGLES N/A</td> <td></td> <td></td> </tr> </table> | | GENERAL TOLERANCES | DRAWN BY: Kelly | 2024/12/30 | .X ±0.2 | CHK'D BY: Chili | 2024/12/30 | .XX ±0.2 | | | .XXX ±0.2 | | | ANGLES N/A | | |
| GENERAL TOLERANCES | DRAWN BY: Kelly | 2024/12/30 | | | | | | | | | | | | | | | | | | | |
| .X ±0.2 | CHK'D BY: Chili | 2024/12/30 | | | | | | | | | | | | | | | | | | | |
| .XX ±0.2 | | | | | | | | | | | | | | | | | | | | | |
| .XXX ±0.2 | | | | | | | | | | | | | | | | | | | | | |
| ANGLES N/A | | | | | | | | | | | | | | | | | | | | | |
| 01 | BODY | BRASS | NICKEL | 1 |  REV. 2.10 | | | | | | | | | | | | | | | | |
| NO | DESCRIPTION | MATERIAL | FINISH | Q'TY | | | SHEET 1 of 1 | Unit: mm | | | | | | | | | | | | | |