

REV	DESCRIPTION	DATE
1.00	INITIAL DESIGN	2022/08/19
2.00	UPDATE DRAWING	2023/05/08

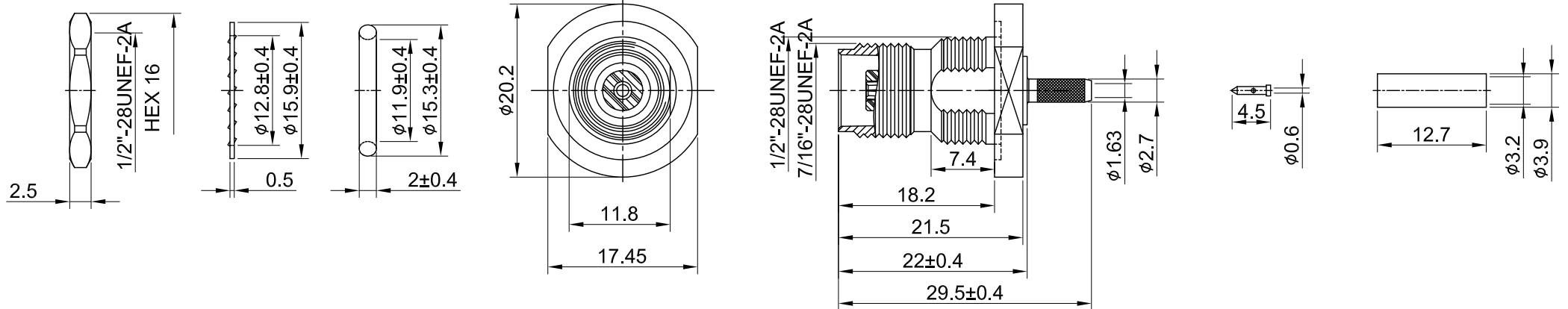
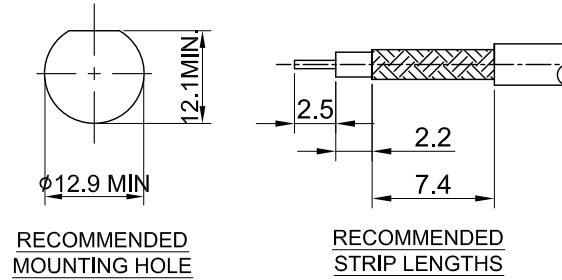

MECHANICAL DATA
 DURABILITY : 100 CYCLES
 TEMPERATURE RANGE : -65°C ~ + 165°C

DIELECTRICAL DATA
 FREQUENCY RANGE: DC~6GHz
 IMPEDANCE : 50Ω
 VSWR : 1.5 MAX.
 WORKING VOLTAGE : AC 500V
 WITHSTANDING VOLTAGE : AC 1500V
 INSULATION RESISTANCE : 5000 mΩ MIN

09	NUT	BRASS	NICKEL	1
08	WASHER	BRASS	NICKEL	1
07	O RING	SILICONE RUBBER	BLACK	1
06	FERRULE	BRASS	NICKEL	1
05	BULLET CONTACT	BRASS	GOLD	1
04	BODY B	BRASS	NICKEL	1
03	INSULATOR	TEFLON	NONE	1
02	CENTER PIN	P.BRONZE	GOLD	1
01	BODY A	BRASS	NICKEL	1
NO	DESCRIPTION	MATERIAL	FINISH	Q'TY

TITLE		DRAWN BY: Kelly		2023/05/08											
TNC(F) bh. wOring for RG174, pin in pin		CHK'D BY: Chilli		2023/05/08											
DWG NO. C18CDWS174019B				REV.											
CUST. P/N: N/A		<table border="1"> <tr> <td>GENERAL TOLERANCES</td> <td></td> </tr> <tr> <td>.X</td> <td>±0.2</td> </tr> <tr> <td>.XX</td> <td>±0.2</td> </tr> <tr> <td>.XXX</td> <td>±0.2</td> </tr> <tr> <td>ANGLES</td> <td>N/A</td> </tr> </table>		GENERAL TOLERANCES		.X	±0.2	.XX	±0.2	.XXX	±0.2	ANGLES	N/A		2.00
GENERAL TOLERANCES															
.X	±0.2														
.XX	±0.2														
.XXX	±0.2														
ANGLES	N/A														
DWG NO: N/A		DA2305050021													
SHEET 1 of 1	Unit: mm														